



Second edition
2015-01-15

**Fibre-reinforced polymer (FRP)
reinforcement of concrete — Test
methods —**

**Part 1:
FRP bars and grids**

*Polymère renforcé par des fibres (PRF) pour l'armature du béton —
Méthodes d'essai —*

Partie 1: Barres et grilles en PRF



Reference number
ISO 10406-1:2015(E)

© ISO 2015



COPYRIGHT PROTECTED DOCUMENT

© ISO 2015

All rights reserved. Unless otherwise specified, no part of this publication may be reproduced or utilized otherwise in any form or by any means, electronic or mechanical, including photocopying, or posting on the internet or an intranet, without prior written permission. Permission can be requested from either ISO at the address below or ISO's member body in the country of the requester.

ISO copyright office
Case postale 56 • CH-1211 Geneva 20
Tel. + 41 22 749 01 11
Fax + 41 22 749 09 47
E-mail copyright@iso.org
Web www.iso.org

Published in Switzerland

Contents

Page

Foreword	v
1 Scope	1
2 Normative references	1
3 Terms, definitions, and symbols	1
3.1 Terms and definitions.....	1
3.2 Symbols.....	5
4 General provision concerning test pieces	6
5 Test method for cross-sectional properties	6
5.1 Test pieces.....	6
5.2 Test method.....	6
5.3 Calculations.....	7
5.4 Test report.....	8
6 Test method for tensile properties	8
6.1 Test pieces.....	8
6.2 Test equipment.....	9
6.3 Test method.....	9
6.4 Calculations.....	9
6.5 Test report.....	11
7 Test method for bond strength by pull-out testing	13
7.1 Test pieces.....	13
7.2 Testing machine and devices.....	15
7.3 Test method.....	16
7.4 Calculations.....	17
7.5 Test report.....	17
8 Test method for performance of anchorages and couplers	18
8.1 Test method for performance of anchorages.....	18
8.2 Test method for performance of couplers.....	19
8.3 Test report.....	19
9 Test method for long-term relaxation	20
9.1 Test pieces.....	20
9.2 Testing frame and devices.....	21
9.3 Test temperature.....	21
9.4 Test method.....	22
9.5 Calculations.....	22
9.6 Test report.....	23
10 Test method for tensile fatigue	23
10.1 Test pieces.....	23
10.2 Testing machine and devices.....	23
10.3 Test temperature.....	24
10.4 Test method.....	24
10.5 Calculations.....	25
10.6 Test report.....	25
11 Test method for alkali resistance	25
11.1 Test pieces.....	25
11.2 Immersion in alkaline solution.....	26
11.3 External appearance and mass change.....	26
11.4 Tensile test.....	27
11.5 Calculations.....	27
11.6 Test report.....	28
12 Test method for creep failure	29

12.1	Test pieces.....	29
12.2	Testing frame and devices.....	29
12.3	Test temperature.....	29
12.4	Tensile capacity.....	29
12.5	Test method.....	29
12.6	Calculations.....	30
12.7	Test report.....	30
13	Test method for transverse shear strength.....	31
13.1	Test pieces.....	31
13.2	Testing machine and devices.....	31
13.3	Test temperature.....	32
13.4	Test method.....	33
13.5	Calculations.....	33
13.6	Test report.....	33
14	Test method for flexural tensile properties.....	34
14.1	Test pieces.....	34
14.2	Testing unit and devices.....	34
14.3	Test method.....	35
14.4	Calculations.....	35
14.5	Test report.....	35
15	Test method for the coefficient of longitudinal thermal expansion by thermo- mechanical analysis.....	36
15.1	Test pieces.....	36
15.2	Testing device.....	37
15.3	Test method.....	37
15.4	Calculations.....	38
15.5	Test report.....	38

Foreword

ISO (the International Organization for Standardization) is a worldwide federation of national standards bodies (ISO member bodies). The work of preparing International Standards is normally carried out through ISO technical committees. Each member body interested in a subject for which a technical committee has been established has the right to be represented on that committee. International organizations, governmental and non-governmental, in liaison with ISO, also take part in the work. ISO collaborates closely with the International Electrotechnical Commission (IEC) on all matters of electrotechnical standardization.

The procedures used to develop this document and those intended for its further maintenance are described in the ISO/IEC Directives, Part 1. In particular the different approval criteria needed for the different types of ISO documents should be noted. This document was drafted in accordance with the editorial rules of the ISO/IEC Directives, Part 2 (see www.iso.org/directives).

Attention is drawn to the possibility that some of the elements of this document may be the subject of patent rights. ISO shall not be held responsible for identifying any or all such patent rights. Details of any patent rights identified during the development of the document will be in the Introduction and/or on the ISO list of patent declarations received (see www.iso.org/patents).

Any trade name used in this document is information given for the convenience of users and does not constitute an endorsement.

For an explanation on the meaning of ISO specific terms and expressions related to conformity assessment, as well as information about ISO's adherence to the WTO principles in the Technical Barriers to Trade (TBT), see the following URL: Foreword — Supplementary information.

The committee responsible for this document is ISO/TC 71, *Concrete, reinforced concrete and pre-stressed concrete*, Subcommittee SC 6, *Non-traditional reinforcing materials for concrete structures*.

This second edition cancels and replaces the first edition (ISO 10406-1:2008), which has been technically revised.

ISO 10406 consists of the following parts, under the general title *Fibre-reinforced polymer (FRP) reinforcement of concrete — Test methods*:

- Part 1: FRP bars and grids
- Part 2: FRP sheets

Fibre-reinforced polymer (FRP) reinforcement of concrete — Test methods —

Part 1: FRP bars and grids

1 Scope

This part of ISO 10406 specifies test methods applicable to fibre-reinforced polymer (FRP) bars and grids as reinforcements or pre-stressing tendons in concrete.

2 Normative references

The following documents, in whole or in part, are normatively referenced in this document and are indispensable for its application. For dated references, only the edition cited applies. For undated references, the latest edition of the referenced document (including any amendments) applies.

ISO 291:2008, *Plastics — Standard atmospheres for conditioning and testing*

ISO 3611, *Geometrical product specifications (GPS) — Dimensional measuring equipment: Micrometers for external measurements — Design and metrological characteristics*

ISO 4788, *Laboratory glassware — Graduated measuring cylinders*

ISO 7500-1, *Metallic materials — Verification of static uniaxial testing machines — Part 1: Tension/compression testing machines — Verification and calibration of the force-measuring system*

ISO 13385-1, *Geometrical product specifications (GPS) — Dimensional measuring equipment — Part 1: Callipers; Design and metrological characteristics*

3 Terms, definitions, and symbols

3.1 Terms and definitions

For the purposes of this document, the following terms and definitions apply.

3.1.1

alkalinity

condition of having or containing hydroxyl (OH⁻) ions; containing alkaline substances

Note 1 to entry: In concrete, the initial alkaline environment has a pH above 13.

3.1.2

anchorage reinforcement

lattice or spiral reinforcing steel or FRP connected with the anchorage and arranged behind it

3.1.3

anchoring section

end part of a test piece where an anchorage is fitted to transmit loads from the testing machine to the test section

Fibre-reinforced polymer (FRP) reinforcement of concrete — Test methods —

Part 1: FRP bars and grids

1 Scope

This part of ISO 10406 specifies test methods applicable to fibre-reinforced polymer (FRP) bars and grids as reinforcements or pre-stressing tendons in concrete.

2 Normative references

The following documents, in whole or in part, are normatively referenced in this document and are indispensable for its application. For dated references, only the edition cited applies. For undated references, the latest edition of the referenced document (including any amendments) applies.

ISO 291:2008, *Plastics — Standard atmospheres for conditioning and testing*

ISO 3611, *Geometrical product specifications (GPS) — Dimensional measuring equipment: Micrometers for external measurements — Design and metrological characteristics*

ISO 4788, *Laboratory glassware — Graduated measuring cylinders*

ISO 7500-1, *Metallic materials — Verification of static uniaxial testing machines — Part 1: Tension/compression testing machines — Verification and calibration of the force-measuring system*

ISO 13385-1, *Geometrical product specifications (GPS) — Dimensional measuring equipment — Part 1: Callipers; Design and metrological characteristics*

3 Terms, definitions, and symbols

3.1 Terms and definitions

For the purposes of this document, the following terms and definitions apply.

3.1.1 alkalinity

condition of having or containing hydroxyl (OH⁻) ions; containing alkaline substances

Note 1 to entry: In concrete, the initial alkaline environment has a pH above 13.

3.1.2 anchorage reinforcement

lattice or spiral reinforcing steel or FRP connected with the anchorage and arranged behind it

3.1.3 anchoring section

end part of a test piece where an anchorage is fitted to transmit loads from the testing machine to the test section

3.1.4

average load

<stress> average of the maximum and minimum repeated load (stress)

3.1.5

bending angle

angle formed by the straight sections of a test piece on either side of the deflector

3.1.6

bending diameter ratio

ratio of the external diameter of the deflector surface in contact with the FRP bar, and the nominal diameter of the FRP bar

3.1.7

bending tensile capacity

tensile load at the moment of failure of the test piece

3.1.8

coefficient of thermal expansion

average coefficient of linear thermal expansion between given temperatures

Note 1 to entry: The average of the given temperatures is taken as the representative temperature.

3.1.9

continuous fibre

general term for continuous fibres of materials such as carbon, aramid, and glass

3.1.10

coupler

device coupling tendons

3.1.11

creep failure capacity

load causing failure after a specified period of time from the start of a sustained load

Note 1 to entry: In particular, the load causing failure after 1 million hours is referred to as the million-hour creep failure capacity.

3.1.12

creep failure strength

stress causing failure after a specified period of time from the start of a sustained load

Note 1 to entry: In particular, the load causing failure after 1 million hours is referred to as the million-hour creep failure strength.

3.1.13

creep failure time

time between the start of a sustained load and failure of a test piece

3.1.14

creep failure

failure occurring in a test piece due to a sustained load

3.1.15

creep strain

differential change in length per unit length occurring in a test piece due to creep

3.1.16

creep

time-dependent deformation of an FRP bar subjected to a sustained load at a constant temperature

3.1.17**deflected section**

section of an FRP bar that is bent and maintained at the required bending angle and bending diameter ratio

3.1.18**deflector**

device used to maintain the position, alter the bending angle, or alleviate the stress concentrations in the FRP bar and which is sometimes installed in the deflected section

3.1.19**fatigue strength**

maximum repeated stress at which the test piece does not fail at the prescribed number of cycles

3.1.20**fibre-reinforced polymer****FRP**

composite material, moulded and hardened to the intended shape, consisting of continuous fibres impregnated with a fibre-binding polymer

3.1.21**frequency**

number of loading (stressing) cycles in 1 s during the test

3.1.22**FRP bar**

composite material formed into a long, slender structural shape suitable for use as reinforcement in concrete and consisting primarily of longitudinal unidirectional fibres bound and shaped by a rigid polymer resin material

3.1.23**gauge length**

straight portion along the length of a test piece used to measure the elongation using an extensometer or a similar device

3.1.24**grid**

two-dimensional (planar) or three-dimensional (spatial) rigid array of interconnected FRP bars that form a continuous lattice that can be used to reinforce concrete

3.1.25**load amplitude****load (stress) amplitude**

one-half of the load (stress) range

3.1.26**load (stress) range**

difference between maximum and minimum repeated load (stress)

3.1.27**maximum repeated load (stress)**

maximum load (stress) during repeated loading

3.1.28**maximum tensile force**

maximum tensile load sustained by a test piece during the tensile test

3.1.29**minimum repeated load (stress)**

minimum load (stress) during repeated loading

3.1.30

nominal cross-sectional area

value obtained upon dividing the volume of the FRP specimen by its length

3.1.31

nominal diameter

diameter of FRP calculated assuming a circular section

3.1.32

nominal peripheral length

peripheral length of the FRP that forms the basis for calculating the bond strength and that shall be determined separately for each FRP

3.1.33

number of cycles

number of times the repeated load (stress) is applied to the test piece

3.1.34

relaxation

stress relaxation

time-dependent decrease in load in an FRP held at a given constant temperature with a prescribed initial load applied and held at a given constant strain

3.1.35

relaxation rate

percentage reduction in load relative to the initial load after a given period of time, under a fixed strain

Note 1 to entry: In particular, the relaxation value after 1 million hours (approximately 114 years) is referred to as the hundred-year relaxation rate.

3.1.36

repeated load (stress)

load (stress) alternating cyclically between fixed maximum and minimum values

3.1.37

S-N curve

curve plotted on a graph with repeated stress on the vertical axis and the number of cycles to fatigue failure on the horizontal axis

3.1.38

tendon

FRP

resin-bound construction made of continuous fibres in the shape of a tendon used to reinforce concrete uniaxially

Note 1 to entry: Tendons are usually used in pre-stressed concrete.

3.1.39

thermo-mechanical analysis

TMA

method for measuring deformation of a material as a function of either temperature or time, by varying the temperature of the material according to a calibrated programme, under a non-vibrating load

3.1.40

TMA curve

<TMA> graph with temperature or time represented on the horizontal axis and deformation on the vertical axis

3.1.41

ultimate strain

strain corresponding to the maximum tensile force

3.2 Symbols

See Table 1.

Table 1 — Symbols

Symbol	Unit	Description	Reference
A	mm ²	Nominal cross-sectional area of test piece	5.3, 6.4
D	mm	Nominal diameter	5.3
E	N/mm ²	Young's modulus	6.4
F_u	N	Maximum tensile force	6.4
f_u	N/mm ²	Tensile strength	6.4
ε_u	—	Ultimate strain	6.4
ΔF	N	Difference between loads at 20 % and 50 % of maximum tensile force	6.4
$\Delta \varepsilon$	—	Strain difference between ΔF	6.4
τ	N/mm ²	Bond stress	7.4
P	N	Tensile load in the pull-out test	7.4
u	mm	Nominal peripheral length of test piece	7.4
l	mm	Bonded length	7.4
Y	%	Relaxation rate	9.5.2
t	h	Time	9.5.2
k_a	—	Empirical constant	9.5.2
k_b	—	Empirical constant	9.5.2
$R_{\Delta m}$	%	Mass loss ratio	
V_o	mm ³	Volume of water in the measuring cylinder	5.3
V_s	mm ³	Volume of the sum total of water and test piece	5.3
l_o	mm	Length of test piece	5.3
m_o	g	Mass before immersion	11.4
L_o	mm	Length before immersion	11.4
m_1	g	Mass after immersion	11.4
L_1	mm	Length after immersion	11.4
R_{et}	%	Tensile capacity retention rate	11.5.2
F_{u1}	N	Tensile capacity before immersion	11.5.2
F_{u0}	N	Tensile capacity after immersion	11.5.2
$R_{\gamma c}$	—	Creep load ratio	12.6.3
τ_s	N/mm ²	Shear stress	13.5.2
P_s	N	Shear failure load	13.5.2
α_{sp}	1/°C	Coefficient of thermal expansion	15.4.1
ΔL_{spm}	μ	Difference in length of test piece between temperatures T_1 and T_2	15.4.1
ΔL_{retim}	μ	Difference in length of specification test piece for length calibration between temperatures T_1 and T_2	15.4.1
L_o	m	Length of test piece at room temperature	15.4.1

Table 1 (continued)

Symbol	Unit	Description	Reference
T_2	°C	Maximum temperature for calculation of coefficient of thermal expansion (normally 60 °C)	<u>15.4.1</u>
T_1	°C	Minimum temperature for calculation of coefficient of thermal expansion (normally 0 °C)	<u>15.4.1</u>
α_{set}	1/°C	Coefficient of thermal expansion calculated for specification test piece for length calibration between temperatures T_1 and T_2	<u>15.4.1</u>

4 General provision concerning test pieces

Unless otherwise agreed, test pieces shall be taken from the bar or grid in the “as-delivered” condition.

In cases where test pieces are taken from a coil, they shall be straightened prior to any test by a simple bending operation with a minimum amount of plastic deformation.

For the determination of the mechanical properties in the tensile, bond, and anchorage tests, the test piece may be artificially aged (after straightening, if applicable) depending on the performance requirements of the product.

When a test piece is “aged”, the conditions of the ageing treatment shall be stated in the test report.

5 Test method for cross-sectional properties

5.1 Test pieces

5.1.1 Preparation of test pieces

Test pieces shall be cut to a predetermined length and finished flat at their cut end from the mother material (FRP) for tensile test.

5.1.2 Length of test pieces

The length of test pieces shall be 100 mm when approximate nominal diameter is 20 mm or less, and shall be 200 mm when approximate diameter is over 20 mm.

5.1.3 Number of test pieces

The number of test pieces is at least three, taken from the mother material of the same lot.

5.2 Test method

The test procedure is as follows.

- a) Measure the length of the test piece using the vernier callipers in accordance with ISO 13385-1. Measure a part and record the result to three places; round off the three averaged values to one place after the decimal point. Take this as the length of the test piece.
- b) Measure the volume of the test piece using a measuring cylinder in accordance with ISO 4788:2005, type 1a or 1b (class A or class B), according to the approximate diameter of the test piece. Table 2 shows the relationship between the approximate diameter of the test piece and the capacity of the measuring cylinder. When two capacities are listed, choose the smaller-capacity cylinder for that range.

- c) Add the proper quantity of water to the measuring cylinder and measure the volume. When the test piece is in the measuring cylinder, the water should cover the test piece and the top of the water shall be in the range of scale.

NOTE If air bubbles are generated on the surface of the test piece, which can cause an error of measurement, a surface-tension-reducing solvent, such as ethanol, can be added to the water for the purpose of controlling the generation of air bubbles.

- d) Insert the test piece into the measuring cylinder and measure the volume of the combined water and the test piece.
- e) The test temperature shall be within the range of 15 °C to 25 °C. The temperature range of 20 °C to 30 °C is applicable for warm countries.

Table 2 — Relationship between the approximate diameter of test piece and the capacity of measuring cylinder

Approximate diameter of test piece mm	Capacity of measuring cylinder ml
under 10	10 or 20
11 to 13	25
14 to 20	50 or 100
21 to 25	100
over 25	300 or 500

5.3 Calculations

Calculate the nominal cross-sectional area, A , of the test piece from Formula (1) and round off to one place after the decimal point:

$$A = \frac{V_s - V_o}{l_o} \quad (1)$$

where

V_s is the volume of the sum total of water and test piece, expressed in cubic millimetres;

V_o is the volume of water in the measuring cylinder, expressed in cubic millimetres;

l_o is the length of the test piece, expressed in millimetres.

NOTE The nominal cross-sectional area includes the area of surface-bonded sand particles, surface-bonded transverse wraps, and other non-load-bearing areas.

Calculate the nominal diameter, D , from Formula (2) and round off to one place after the decimal point:

$$D = 2\sqrt{\frac{A}{\pi}} \quad (2)$$

where

A is the nominal cross-sectional area, expressed in square millimetres.

5.4 Test report

5.4.1 Mandatory information

The test report shall include the following items:

- a) date of testing;
- b) name, shape, date of manufacture, and lot number of FRP tested;
- c) nominal cross-sectional area;
- d) nominal diameter.

5.4.2 Additional information

The test report may include the following additional items:

- a) capacity of measuring cylinder used in the test;
- b) length of test piece;
- c) volume of water in the measuring cylinder;
- d) volume of the sum total of water and the test piece;
- e) name of the solvent, if any solvent is used in the test.

6 Test method for tensile properties

6.1 Test pieces

6.1.1 Preparation of test pieces

Cut test pieces to predetermined length in accordance with 6.1.2, in such a way as not to affect the performance of the part being tested. For FRP grids, linear test pieces can be prepared by cutting away the extraneous part. Leaving a 2 mm projection of the crossbars is recommended.

6.1.2 Length of test pieces

The length of test pieces shall be taken to be the sum of the length of the test section and the anchoring section (see Figure 1).

The length of the test section shall be taken to be as follows.

- a) For bars, the length shall be not less than 300 mm and not less than 40 times the nominal diameter.
- b) For strands, the length shall be in accordance with the provision in 6.1.2 a) and not less than 2 times the strand pitch.
- c) For grids, the length shall be in accordance with the provision in 6.1.2 a) and shall include not less than three cross-points.

6.1.3 Storage of test pieces

Store the test pieces carefully and protect against deformation, heating, and exposure to ultraviolet light, which can cause changes to the material properties of the test pieces.

6.1.4 Number of test pieces

The total number of test pieces shall be at least five.

6.2 Test equipment

6.2.1 Testing machine

The testing machine should conform to the requirements for the tension-testing machine in accordance with ISO 7500-1.

6.2.2 Anchorage

The anchorage shall be suited to the geometry of the test pieces and shall have the capacity to transmit only the tensile force along the longitudinal axis of the test pieces.

6.2.3 Extensometers and strain gauges

The extensometers and strain gauges used to measure the elongation of the test piece under loading shall be capable of recording variations in the gauge length or elongation during testing with an accuracy of at least 10^{-5} . The gauge length of the extensometer shall be not less than 100 mm and not less than 8 times the nominal diameter of the FRP bar. For stranded bars, in addition to the above provision, the gauge length shall not be less than the strand pitch (see [Figure 1](#)). In systems with an unbonded external sheath, make sure that the extensometer is measuring the strain in the core fibre, not that in the sheath.

6.3 Test method

6.3.1 Mounting of the test piece

Mount the test piece on the testing machine, such that only the axial load is transmitted (see [Figure 2](#)).

6.3.2 Mounting of extensometer

Mount the extensometer along the axis of the central portion of the test piece.

6.3.3 Loading method

Carry out the loading in accordance with the following requirements.

- a) Apply the load at a constant rate without impact to the test piece. The rate of loading shall be 0,5 % to 1,5 % strain per minute. The test time shall not exceed 5 min.
- b) Measure the strain at not fewer than 10 equally spaced loading increments until approximately two thirds of the maximum tensile force.
- c) Record the maximum tensile force with a precision of three significant digits.

6.3.4 Test temperature

The test temperature shall be within the range of 5 °C to 35 °C.

6.4 Calculations

6.4.1 General

All results, except for the cases where the location of the failure position is within anchorage, shall be used as a rule. However, if the failure location is often found to be within anchorage, the results of the

failure within anchorage may be included. In cases when a result (in terms of the maximum tensile force) deviates by 10 % or more from the average value, that result shall be ignored and only the four remaining results shall be used. In such cases, if one result deviates by 10 % or more from the average value calculated using the four results, all results shall be rejected and a new test shall be performed. Rejected test results shall not be used for the calculation of tensile rigidity, Young's modulus, or ultimate strain.

The average, \bar{x} , deviation, Δx_i , and standard deviation, σ , are defined as given in Formulae (3) to (5), respectively:

$$\bar{x} = \frac{1}{N} \sum_{i=1}^N x_i \quad (3)$$

$$\Delta x_i = x_i - \bar{x} \quad (4)$$

$$\sigma = \sqrt{\frac{1}{N} \sum_{i=1}^N (x_i - \bar{x})^2} \quad (5)$$

where

N is the number of test pieces;

x_i are the sampling data.

6.4.2 Cross-sectional area

The cross-sectional area shall be the nominal cross-sectional area calculated in accordance with [Clause 5](#). If the standard cross-sectional area is reported by the manufacturer of the FRP, the standard cross-sectional area may be used as the cross-sectional area. It is necessary to include the nominal cross-sectional area, effective fibre area, polymer area, and fibre strength in the value of the standard cross-sectional area.

6.4.3 Tensile strength

Calculate the tensile strength, f_u , expressed in newtons per square millimetre, to a precision of three significant digits using Formula (6):

$$f_u = F_u / A \quad (6)$$

where

F_u is the maximum tensile force, expressed in newtons;

A is the cross-sectional area, expressed in square millimetres.

6.4.4 Tensile rigidity and Young's modulus

Calculate the tensile rigidity, E_A , expressed in newtons and Young's modulus, E , expressed in newtons per square millimetre, both to a precision of three significant digits, using Formulae (7) and (8), respectively. It shall be calculated from the difference between the load (stress)-strain curve obtained from the load level at 20 % and 50 % of the tensile capacity. For materials where a guaranteed tensile capacity is given, the values at 20 % and 50 % of the guaranteed tensile capacity may be used.

$$E_A = \frac{\Delta F}{\Delta \varepsilon} \quad (7)$$

$$E = \frac{\Delta F}{\Delta \varepsilon \times A} \quad (8)$$

where

ΔF is the difference between loads at 20 % and 50 % of the maximum tensile force, expressed in newtons;

$\Delta \varepsilon$ is the strain difference for ΔF .

6.4.5 Ultimate strain

Ultimate strain shall be the strain corresponding to the ultimate tensile capacity when strain-gauge measurements of the test piece are available up to failure. In the event that the measurements from an extensometer or strain gauge are not available up to failure, the ultimate strain, ε_u , shall be calculated to a precision of three significant digits using Formula (9):

$$\varepsilon_u = \frac{F_u}{E \times A} \quad (9)$$

6.5 Test report

6.5.1 Mandatory information

The test report shall include the following items:

- a) name, shape, date of manufacture, and lot number of FRP tested;
- b) type of fibre and fibre binding polymer;
- c) numbers or identification marks of test pieces;
- d) designation, nominal cross-sectional area, and diameter;
- e) date of testing, temperature, loading rate;
- f) calculation method;
- g) average and standard deviation of the maximum tensile force (strength), and maximum tensile force (strength) for each test piece;
- h) tensile rigidity and Young's modulus for each test piece and average;
- i) average ultimate strain and ultimate strain for each test piece;
- j) stress-strain curve for each test piece;
- k) mode of failure for each test piece;
- l) name of person in charge of carrying out the test.

6.5.2 Additional information

When the standard cross-sectional area is used as the cross-sectional area, the following may be added:

- a) standard cross-sectional area, diameter, and assumed polymer area;
- b) average and standard deviation of the maximum tensile strength, and maximum tensile strength for each test piece;

- c) Young's modulus for each test piece and average;
- d) stress-strain curve for each test piece;
- e) fibre strength.

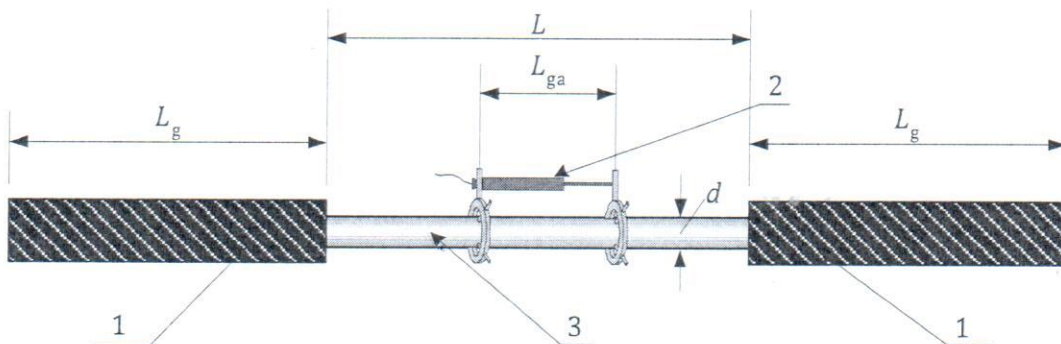

$$L_{\text{tot}} = L + 2 L_g$$

length of test section, L

gauge length, L_{ga}

- bar : $L \geq 300 \text{ mm}, 40 d$

- bar, grid : $L_{\text{ga}} \geq 100 \text{ mm}, 8 d$

- strand : $L \geq 300 \text{ mm}, 40 d, 2 \text{ strand-pitch}$

- strand : $L_{\text{ga}} \geq 100 \text{ mm}, 8 d, \text{strand-pitch}$

- grid : $L \geq 300 \text{ mm}, 40 d, 3 \text{ cross-points}$

Key

- 1 anchoring section
- 2 extensometer
- 3 test section

Figure 1 — Test piece for tensile test

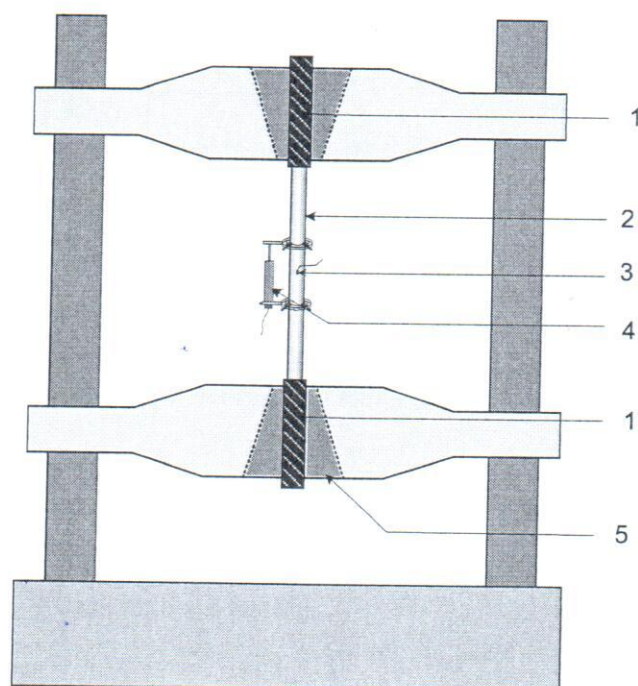
**Key**

- 1 anchoring section
- 2 FRP rod
- 3 strain gauge
- 4 extensometer
- 5 anchoring devices

Figure 2 — Outline of tensile test

7 Test method for bond strength by pull-out testing

7.1 Test pieces

The provisions of [6.1](#) shall apply.

7.1.1 Fabrication of test pieces

Test pieces should normally be cubes, with a single FRP bar embedded vertically along the central axis (see [Figure 3](#)). The bonded length of the FRP bar shall be a typical section of the surface of the FRP bar and shall be located at the free-end side of the test pieces. The bonded length of the FRP bar shall be four times the diameter of the FRP bar. In order to equalize the stress from the loading plate on the loaded side, the embedded bar outside the bonded section shall be sheathed with PVC or other suitable material to prevent bonding.

7.1.2 Dimensions of test pieces

Determine the dimensions of the test pieces as a function of the nominal diameter of the FRP bars as shown in [Table 3](#) (see also [Figure 3](#)).

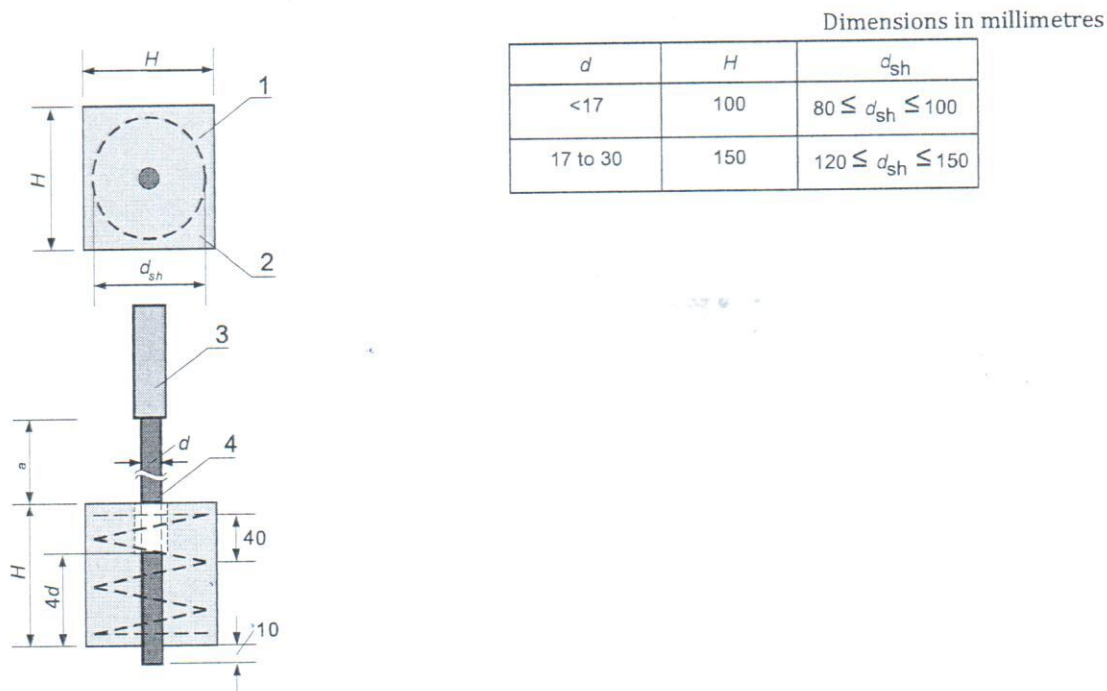

Key

- 1 spiral reinforcement $\phi - 6$
- 2 concrete prism
- 3 anchoring section
- 4 FRP bar
- ^a At least 300 mm and 40d

Figure 3 — Test piece for bond test (pull-out test)

Table 3 — Dimensions of test pieces

FRP nominal diameter mm	Size of cube ^a mm	Bonded length	External diameter of spiral reinforcement d_{sh} mm
<17	100 × 100 × 100	4 times nominal diameter	$80 \leq d_{sh} \leq 100$
17 to 30	150 × 150 × 150	4 times nominal diameter	$120 \leq d_{sh} \leq 150$

^a If it is necessary to test bars larger than 30 mm in diameter, the size of the concrete cube may be increased accordingly.

7.1.3 Dimensions of FRP bars

Allow the FRP bar to protrude by around 10 mm at the free-end side and structure the end face so as to allow the attachment of a dial gauge, etc., for measuring the length of pull-out. The loading end of the FRP bar shall be extended sufficiently to allow the pull-out test to be carried out, and shall be fitted with an anchoring section, gripping device, or similar apparatus capable of transmitting axial loads to the FRP bar.

7.1.4 Arrangement of FRP bars

Arrange the FRP bars on the central axis of the test piece.

7.1.5 Spiral reinforcements

Test pieces can be provided with spiral reinforcements along the central axis to prevent splitting failure. Spiral reinforcements shall be 6 mm in diameter, with a spiral pitch of 40 mm. The external diameter of spiral reinforcements is dependent on the nominal diameter of the FRP bars as specified in Table 3. The ends of the spiral reinforcements shall be welded, or 1,5 times extra turns shall be provided.

7.1.6 Number of test pieces

Test at least three test pieces. When a test piece fails at, or slips out of, the anchoring section, carry out an additional test on a separate test piece prepared using FRP bars from the same lot as the failed test piece.

7.1.7 Concrete quality

Make up the concrete with normal aggregates, with the coarse aggregates having a maximum dimension of 20 mm or 25 mm. The concrete shall have a slump of $10 \text{ cm} \pm 2 \text{ cm}$, and a 28-day cylinder compressive strength of $30 \text{ N/mm}^2 \pm 3 \text{ N/mm}^2$ for bond testing.

7.1.8 Placing of concrete

- Clean the bonding section of the FRP bar and render it free from any grease, dirt, etc.
- Take suitable measures before placing the concrete to prevent bonding of the non-bonding sections of the FRP bar.
- Seal the opening in the form through which the FRP bar is inserted to prevent ingress of water, etc., using oil, putty, or similar material.
- Smooth off the test piece after placing the concrete by scraping any excess off the top, repeating this process again after about 2 h to ensure that a test piece with the proper dimensions is obtained.

7.1.9 Removal of forms and curing

Remove the forms after two days and then cure the test pieces in water at a temperature of $20 \text{ }^\circ\text{C} \pm 3 \text{ }^\circ\text{C}$ until the time of testing. The temperature of $27 \text{ }^\circ\text{C} \pm 2 \text{ }^\circ\text{C}$ is applicable for warm countries.

7.2 Testing machine and devices

7.2.1 Testing machine

The testing machine for pull-out tests shall be capable of accurately applying the prescribed load.

7.2.2 Loading plate

The loading plate shall have a hole through which the FRP bar shall pass. The diameter of the hole in the loading plate shall be two times to three times the diameter of the FRP bar.

7.2.3 Anchorage

The loading-end side of the FRP bar shall be fitted with an anchorage capable of transmitting loads accurately until the tendon pulls out due to bond failure, or because of splitting or cracking of the concrete. The load-transmission device shall transmit only axial loads to the FRP bar, without transmitting either torsional or flexural forces.

7.2.4 Displacement measuring device

The displacement meter fitted to the free end of the FRP bar shall be a LVDT or any similar apparatus capable of giving readings with an accuracy of 1/1 000 mm (see [Figure 4](#)).

7.3 Test method

7.3.1 Mounting of test pieces

Place the test piece correctly on the loading plate with a spherical plate underneath to prevent eccentric loads from acting on the test pieces (see [Figure 4](#)).

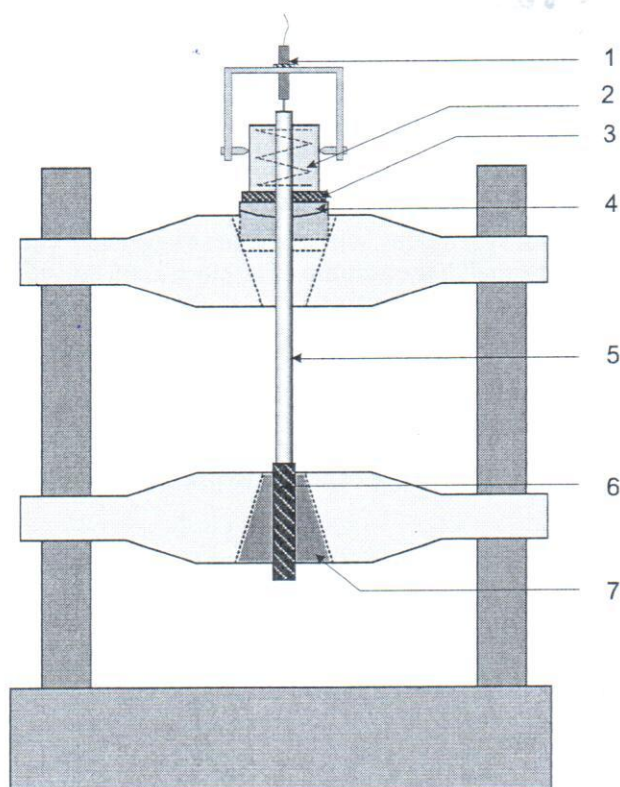

Key

- 1 LVDT
- 2 concrete prism
- 3 loading plate
- 4 spherical plate
- 5 FRP rod
- 6 anchoring section
- 7 anchoring device

Figure 4 — Outline of bond test (pull-out test)

7.3.2 Loading rate

The standard loading rate shall be such that the average tensile stress of the FRP bar increases at a rate of 10 N/mm²/min to 20 N/mm²/min. Keep the loading rate as constant as possible so as not to subject the test pieces to shock.

7.3.3 Scope of test

The slippage of the free end and the load applied shall be recorded in increments as shown in Table 4, until either the FRP bar pulls out of the concrete or the load decreases significantly due to the splitting or cracking of the concrete.

Table 4 — Measurement increments

Slippage of free end mm	Measurement increment mm
<0,1	0,01
0,1 to 0,2	0,02
0,2 to 0,5	0,05
>0,5	0,1

7.3.4 Age of test pieces

The age of the test pieces at the time of testing shall be 28 days.

7.4 Calculations

When a test piece is judged to have undergone tensile failure at the anchoring section or to have slipped out of the anchoring section before the FRP bar slips from the concrete or the load is significantly reduced due to splitting or cracking of the concrete, reject the data and carry out additional test(s) until the number of test pieces slipping from the concrete or where the load is significantly reduced due to splitting or cracking of the concrete is not fewer than three.

Calculate the bond stress, τ , expressed in newtons per square millimetre, to a precision of three significant digits using Formula (10), and plot the curve for the pull-out load or bond stress versus slippage displacement for each test piece.

$$\tau = \frac{P}{u \times l} \quad (10)$$

where

- P is the tensile load in the pull-out test, expressed in newtons;
- u is the nominal peripheral length of test piece, expressed in millimetres;
- l is the bonded length, expressed in millimetres.

7.5 Test report

The test report shall include the following items:

- a) name, shape, date of manufacture, and lot number of the FRP tested;
- b) type of fibre and fibre-binding polymer, type of surface treatment of fibres;
- c) numbers or identification marks of test pieces;
- d) designation, nominal cross-sectional area, and diameter;
- e) date of test, test temperature, loading rate;
- f) dimensions of test pieces, bonded length of the FRP bar;

- g) concrete mix, slump, and compressive strength at time of testing;
- h) average and maximum bond stress, and failure mode for each test piece;
- i) bond stress versus slippage displacement curve for each test piece.

8 Test method for performance of anchorages and couplers

8.1 Test method for performance of anchorages

8.1.1 Test pieces

8.1.1.1 Preparation of test pieces

Prepare test pieces by attaching an anchorage to one or both ends of the FRP tendon.

8.1.1.2 Dimensions of test pieces

The recommended length of FRP tendon between abutments is 3 m (see [Figure 5](#)). However, when shorter lengths are used, the length of FRP tendon between anchorages shall not be less than 300 mm nor less than 40 times the nominal diameter.

8.1.1.3 Number of test pieces

Test at least three test pieces.

8.1.2 Test temperature

The test temperature should generally be within the range of 5 °C to 35 °C. If necessary, carry out testing of test pieces from FRP tendons that are sensitive to temperature or that are used at high temperatures at the actual service temperature.

8.1.3 Test method

8.1.3.1 Mounting of test piece

Mount and support the test pieces on the tensile testing machine. Determine the area and geometry of the surface supporting the anchorage, the tension in the FRP tendons, and the manner of application of forces that represents the actual conditions of the pre-stressed concrete structure as closely as possible.

8.1.3.2 Loading rate

The standard loading rate shall be a constant strain rate equivalent to 1 % strain per minute \pm 0,5 %.

8.1.3.3 Scope of test

Continue loading up to the tensile failure, as determined either by the failure of the FRP tendon or by excessive deformation of the anchoring device.

8.1.4 Calculations

Calculate the tensile capacity for each test piece and the average tensile capacity. Record also the modes of failure, noting any deformation, damage, caving in, etc., of the anchorage.

8.2 Test method for performance of couplers

8.2.1 Test pieces

8.2.1.1 Preparation of test pieces

Prepare test pieces by attaching FRP or other tendons to one or both ends of a coupler. Any other tendons and their couplers shall have adequate strength relative to the FRP tendons being tested.

8.2.1.2 Dimensions of test pieces

The recommended length of FRP tendon between abutments is 3 m (see [Figure 6](#)). However, when shorter lengths are used, the length of FRP tendon between anchorage and coupler shall not be less than 300 mm nor less than 40 times the nominal diameter.

8.2.1.3 Number of test pieces

Test at least three test pieces.

8.2.2 Test temperature

The test temperature should generally be within the range of 5 °C to 35 °C. If necessary, carry out the testing of test pieces from FRP tendons that are sensitive to temperature or are used at high temperatures at the actual service temperature.

8.2.3 Test method

The general provisions in [8.1.3](#) shall apply.

8.2.4 Calculations

Calculate the tensile capacity for each test piece and the average tensile capacity. Record also the modes of failure, noting any deformation, damage, caving in, etc., of the couplers.

8.3 Test report

The test report shall include the following items:

- a) name and lot number of FRP tested;
- b) type of fibre and fibre-binding material;
- c) numbers or identification marks of test pieces;
- d) designation, nominal cross-sectional area, and diameter;
- e) date of test, test temperature, loading rate;
- f) dimensions of test pieces and description of anchorage;
- g) average tensile failure capacity, tensile failure capacity, and failure mode for each test piece;
- h) records of any deformation, damage, caving in, etc., of anchorages and couplers.

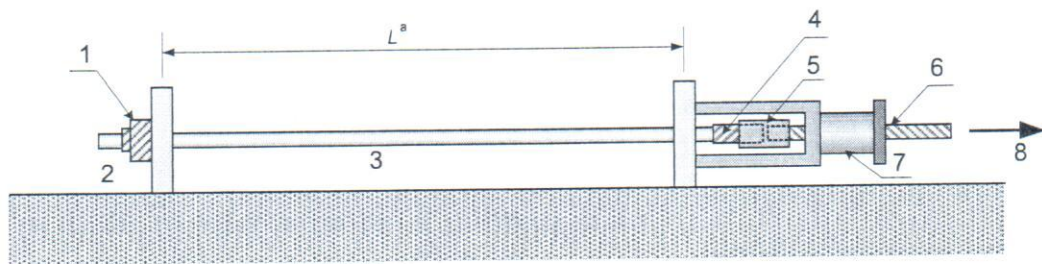

Key

- 1 anchorage (test specimen)
- 2 abutment
- 3 FRP tendon
- 4 anchoring section
- 5 coupler
- 6 pre-stressing steel tendon
- 7 load cell
- 8 force
- ^a L = 3,0 m

Figure 5 — Outline of test for performance of anchorage (example)

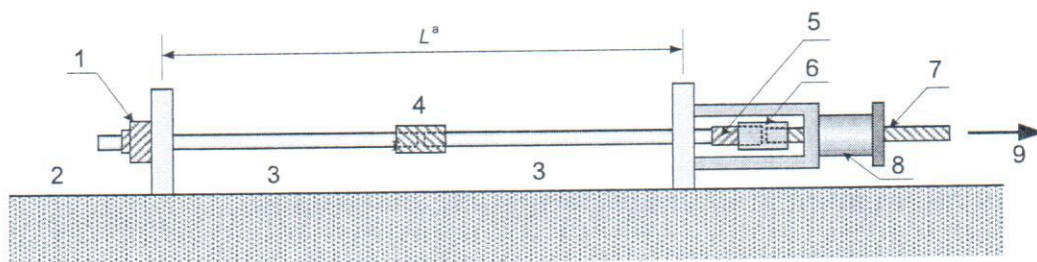

Key

- | | |
|---------------------------|------------------------------|
| 1 anchorage | 6 coupler |
| 2 abutment | 7 pre-stressing steel tendon |
| 3 FRP tendon | 8 load cell |
| 4 coupler (test specimen) | 9 force |
| 5 anchoring section | ^a L = 3,0 m |

Figure 6 — Outline of test for performance of coupler (example)

9 Test method for long-term relaxation

9.1 Test pieces

9.1.1 Preparation, handling and dimensions of test pieces

Prepare and handle test pieces in accordance with the provisions in [Clause 6](#).

9.1.2 Number of test pieces

Test at least three test pieces. In cases when a test piece fails at, or slips out of, the anchoring section, carry out an additional test on a separate test piece taken from the same lot as the failed test piece.

9.2 Testing frame and devices

9.2.1 Testing frame and devices

The testing frame and devices shall be capable of applying a sustained load while maintaining a constant strain. The loading device shall be capable of loading at a constant strain rate equivalent to 1 % strain per minute $\pm 0,5$ %.

9.2.2 Anchorages

The anchorages shall be in accordance with the provisions in [Clause 6](#).

9.2.3 Accuracy of initial load

The accuracy of the initial load applied to the test piece shall be as follows:

- testing frame and devices with loading capacity of ≤ 1 kN: $\pm 1,0$ % of set load;
- testing frame and devices with loading capacity of > 1 kN: $\pm 2,0$ % of set load.

9.2.4 Accuracy of load measurements

The accuracy of readings or automatic recording of loads applied to the test piece shall be within 0,1 % of the initial load.

9.2.5 Strain fluctuations

The test machine shall control strain fluctuations no greater than $\pm 25 \times 10^{-6}$ in the test piece throughout the test period once the strain in the test piece has been fixed. If the FRP slips from the anchoring section, the distance of slippage shall be compensated so as not to affect the test results.

9.2.6 Extensometer and strain gauge

If an extensometer or strain gauge is to be fitted to the test piece, the extensometer or strain gauge shall be in accordance with the provisions in [Clause 6](#).

9.2.7 Measurement of time

The passage of time during the test shall be measured with appropriate equipment (timer, etc.) with an accuracy of within 1 % of the elapsed time.

9.3 Test temperature

The test temperature should normally be within the range of $20\text{ °C} \pm 2\text{ °C}$, except in special circumstances. The temperature of $27\text{ °C} \pm 2\text{ °C}$ is applicable for warm countries. In cases when the temperature has a major effect on the test results, additional tests should be carried out at 0 °C and at 60 °C . In either case, temperature fluctuation over the test period shall be not more than $\pm 2\text{ °C}$.

9.4 Test method

9.4.1 Mounting of test piece and gauge length

Mounting of test pieces and gauge length shall be in accordance with the provisions in Clause 6.

9.4.2 Pre-stretching

In cases when a strain gauge is used for a test piece, the latter shall be stretched taut by applying a load of 10 % to 40 % of the prescribed initial load before fixing and calibrating the strain gauge.

9.4.3 Initial load

The initial load shall be the expected load at transfer. When this load is unknown, the recommended initial load shall be 70 % of the guaranteed tensile capacity.

9.4.4 Application of initial load

- a) The initial load shall be applied without subjecting the test piece to any shock or vibration.
- b) The specified rate of loading the test piece shall be between $200 \text{ N/mm}^2/\text{min} \pm 50 \text{ N/mm}^2/\text{min}$.
- c) The strain on the test piece shall be fixed after the initial load has been applied to the test piece, and maintained for $120 \text{ s} \pm 2 \text{ s}$. This time shall be deemed to be the test start time.

9.4.5 Measurement of load reduction

Load reduction shall generally be measured over a period of at least 1 000 h, unless otherwise agreed. Load reduction shall be recorded automatically by a recorder attached to the testing machine. If no recorder is attached to the testing machine, load reduction shall be measured and recorded after the following times have elapsed unless otherwise agreed: 1 min, 3 min, 6 min, 9 min, 15 min, 30 min, 45 min, 1 h, 1,5 h, 2 h, 4 h, 10 h, 24 h, 48 h, 72 h, 96 h, 120 h. Subsequent measurements shall be taken at least once every 120 h.

9.5 Calculations

9.5.1 Relaxation value

The relaxation value shall be calculated by dividing the load measured in the relaxation test by the initial load.

9.5.2 Relaxation curve

The relaxation curve shall be plotted on a semi-logarithmic graph where the relaxation value, expressed as a percentage, is represented on an arithmetic scale on the vertical axis; and the test time, expressed in hours, is represented on a logarithmic scale on the horizontal axis. An approximation line for the relaxation time, Y , expressed as a percentage, shall be derived from the graph data using the least-squares method as given in Formula (11):

$$Y = k_a - k_b \cdot \log t \quad (11)$$

where

t is the time, expressed in hours;

k_a, k_b are empirical constants.

The coefficient of determination, r^2 , is calculated as given in Formula (12):

$$r^2 = 1 - \frac{\sum_{i=1}^n [Y_i - (k_a - k_b \cdot \log t_i)]^2}{\sum_{i=1}^n (Y_i - \bar{Y})^2} \quad (12)$$

9.6 Test report

The test report shall include the following items:

- a) name, shape, date of manufacture, and lot number of FRP tested;
- b) type of fibre and fibre-binding material;
- c) numbers or identification marks of test pieces;
- d) designation, nominal cross-sectional area, and diameter;
- e) date of test, test temperature, and temperature fluctuations;
- f) type of test machine;
- g) initial load and loading rate of initial load;
- h) guaranteed tensile capacity, and ratio of initial load to guaranteed tensile capacity;
- i) relaxation curve for each test piece;
- j) average relaxation rates at 10 h, 120 h, and 1 000 h;
- k) formula for derivation of an approximation line and its coefficient of determination.

10 Test method for tensile fatigue

10.1 Test pieces

10.1.1 Preparation, handling, and dimensions of test pieces

Preparation, handling, and dimensions of test pieces shall be in accordance with the provisions in [Clause 6](#).

10.1.2 Number of test pieces

Test at least three test pieces for each of the three load levels. If a test piece fails at, or slips out of, the anchoring section, an additional test should be carried out on a separate test piece taken from the same lot as the failed test piece.

10.2 Testing machine and devices

10.2.1 Testing machine

The testing machine shall be capable of maintaining a constant load (stress) amplitude, maximum and minimum repeated load (stress) and frequency. The testing machine shall be fitted with a counter capable of recording the number of cycles to failure of the test piece. The accuracy of the load shall be within 1 % of the load range.

10.2.2 Anchorage

The anchorage shall be in accordance with the provisions in Clause 6. Ideally, the same type of anchorage shall be used for all test pieces in a given series of tests.

10.2.3 Strain measurements

If strain measurements are required as part of the fatigue tests, an extensometer and strain gauge capable of maintaining an accuracy of ± 1 % of the indicated value during the test shall be used.

10.3 Test temperature

The test temperature should generally be within the range 5 °C to 35 °C. The specified test temperature for test pieces sensitive to temperature variations shall be $20\text{ °C} \pm 2\text{ °C}$. The temperature of $27\text{ °C} \pm 2\text{ °C}$ is applicable for warm countries.

10.4 Test method

10.4.1 Mounting of test pieces

Mounting of test pieces shall be in accordance with the provisions in Clause 6.

10.4.2 Load setting

For the purpose of determining an *S-N* curve, set the maximum and minimum loads by one of the following three methods.

- a) Fix the average load and vary the load amplitude.
- b) Fix the minimum load and vary the maximum load.
- c) Fix the load ratio and vary the maximum and minimum load according to this fixed ratio.

Determine the method adopted according to the purpose of the test. In any case, at least three load levels shall be set such that the range of number of cycles to failure is between 10^3 to 2×10^6 . Typical *S-N* curves for FRP materials to utilize a fixed load (stress) ratio, *R*, of 0,1.

10.4.3 Frequency

The frequency should normally be within the range of 1 Hz to 10 Hz.

10.4.4 Start of test

After static loading up to the average load, commence repeated loading. Introduce the prescribed load rapidly and without any shock. The maximum and minimum repeated loads shall remain constant for the duration of the test. Counting of the number of cycles should normally commence when the load on the test piece has reached the prescribed load.

10.4.5 End of test

Complete separation (breaking) of the test piece shall be deemed to constitute failure; record the number of cycles to failure. If the test piece does not fail after 2×10^6 cycles, the test may be discontinued. Do not reuse test pieces that did not fail.

10.4.6 Interruption of test

Tests should normally be conducted without interruption for each test piece from the start to the end of the test. When a test is interrupted, record the number of cycles up to the time of interruption and the period of the interruption.

10.5 Calculations

10.5.1 General

Disregard data for test pieces that slipped from the anchoring section in assessing the material properties of FRP. In cases where tensile failure or slippage has clearly taken place at the anchoring section, disregard the data. Additional tests should be carried out until the number of test pieces failing in the test section is not fewer than three.

10.5.2 S-N curve

Plot the *S-N* curve with the maximum repeated stress, stress range, or stress amplitude represented on an arithmetic scale on the vertical axis, and the number of cycles represented on a logarithmic scale on the horizontal axis. Where measurement points coincide, note the number of coinciding points. Add right-facing arrows to indicate points representing test results for remaining test pieces that did not fail.

10.5.3 Fatigue strength

Derive the fatigue strength at 2×10^6 cycles by interpolation on an *S-N* curve obtained by one of three load section methods [see 10.4.2 a), b), or c)] discussed above. Report the fatigue strength to a precision of three significant digits.

10.6 Test report

The test report shall include the following items:

- a) name, shape, date of manufacture, and lot number of FRP tested;
- b) type of fibre and fibre-binding material;
- c) numbers or identification marks of test pieces;
- d) designation, nominal cross-sectional area, and diameter;
- e) date of test, test temperature, and humidity (from start to end of test);
- f) maximum load (stress), minimum load (stress), load (stress range), number of cycles to failure, and frequency rate for each test piece;
- g) record of observed failure mode for each test piece;
- h) *S-N* curve and fatigue strength.

11 Test method for alkali resistance

11.1 Test pieces

11.1.1 Preparation of test pieces

Do not subject the test pieces to any processing before testing. For FRP grid, liner test pieces can be prepared by cutting away extraneous parts in such a way as not to affect the performance of the part being tested.

11.1.2 Storage of test pieces

Store the test pieces carefully and protect against all deformation, heating, and exposure to ultraviolet light, which can cause changes to the material properties of the test pieces during sampling and preparation of test pieces.

11.1.3 Length of test pieces

The length of the test section shall not be less than 100 mm, nor less than 40 times the nominal diameter of the FRP bar. For a stranded FRP bar, the length shall be in accordance with the above provisions and not less than 2 times the strand pitch.

11.1.4 Number of test pieces

Test at least five test pieces for pre- and post-immersion tensile testing. In the event that a test piece fails at, or slips out of, the anchoring section, an additional test should be carried out on a separate test piece taken from the same lot as the failed test piece.

11.2 Immersion in alkaline solution

11.2.1 Preparation of alkaline solution

The alkaline solution used for immersion shall have the same composition as the pore solution found in the concrete. The solution should have an initial pH above 13. For example, the composition of the alkaline solution consists of 8,0 g of NaOH and 22,4 g of KOH in 1 l of deionized water.

11.2.2 Prevention of infiltration of solution into test piece

In order to prevent the infiltration of the solution via the ends of the test pieces during immersion, coat both ends of the test pieces with epoxy resin and allow to cure.

11.2.3 Immersion temperature

The specified temperature for immersion shall be $60\text{ °C} \pm 3\text{ °C}$.

11.2.4 Mounting of test piece

Mount the test piece on the immersion apparatus. If necessary, a tensioning load, for example, a load level corresponding to the design stress of FRP reinforcement, shall be applied to the test piece. Prevent the alkaline solution from absorbing CO_2 from the air and from the evaporation of water during immersion.

11.2.5 Period of immersion

The specified immersion period shall be one month.

11.2.6 Post-immersion treatment

Wash the test piece in water after immersion.

11.3 External appearance and mass change

11.3.1 Inspection of alkaline solution

Measure the pH value of the alkaline solution before and after the alkali resistance test.

11.3.2 External appearance

Examine the external appearance of the test piece before and after the alkali resistance test, for comparison of colour, surface condition, and change of shape. If necessary, the test piece may be sectioned and polished, and the condition of the cross-section examined using a microscope.

11.3.3 Measurement of mass change

After immersion, remove from the test piece the ends to which the epoxy resin was applied; dry the test piece and measure the mass until the mass is constant. Calculate the rate of percentage mass loss, $R_{\Delta m}$, using Formula (13):

$$R_{\Delta m} = \left[\frac{(m_0/L_0) - (m_1/L_1)}{m_0/L_0} \right] \times 100 \quad (13)$$

where

m_0 is the mass before immersion, expressed in grams;

L_0 is the length before immersion, expressed in millimetres;

m_1 is the mass after immersion, expressed in grams;

L_1 is the length of test piece from which both ends have been removed after immersion, expressed in millimetres.

11.4 Tensile test

11.4.1 Testing machine and devices

Testing machine and devices shall be in accordance with the provisions in [Clause 6](#).

11.4.2 Test temperature and test method

The test temperature and test method shall be in accordance with the provisions in [Clause 6](#).

11.5 Calculations

11.5.1 General

Assess the material properties of FRP bar only on the basis of test pieces undergoing failure in the test section. If tensile failure or slippage takes place at the anchoring section, disregard the data. Additional tests should be carried out until the number of test pieces failing in the test section is not less than five.

11.5.2 Tensile capacity retention rate

Calculate the tensile capacity retention rate, R_{et} , expressed in percent, with a precision to two significant digits according to Formula (14):

$$R_{et} = \frac{F_{u1}}{F_{u0}} \times 100 \quad (14)$$

where

- F_{u1} is the tensile capacity after immersion, expressed in newtons;
- F_{u0} is the tensile capacity before immersion, expressed in newtons.

11.6 Test report

The test report shall include the following items:

- a) basic information:
 - name, shape, date of manufacture, and lot number of FRP tested;
 - type of fibre and fibre-binding material;
 - numbers or identification marks of test pieces;
 - designation, nominal cross-sectional area, and diameter;
 - date of start and end of immersion;
- b) information related to alkaline solution immersion:
 - composition of alkaline solution, pH, temperature, immersion period, and time;
 - tensioning load and ratio of tensioning load to nominal tensile capacity (if tensioning is not carried out, this fact should be noted);
 - record of observation of external appearance and rate of mass loss;
- c) information related to tensile testing:
 - test temperature and loading rate;
 - average and standard deviation of the tensile capacity (strength) for immersed and non-immersed tests, and tensile capacity for each immersed and non-immersed test piece;
 - average tensile rigidity and average Young's modulus for immersed and non-immersed tests, and tensile rigidity and Young's modulus for each immersed and non-immersed test piece;
 - ultimate strain for all immersed and non-immersed test pieces, and average ultimate strain;
 - tensile capacity retention rate;
 - stress-strain curve for all immersed and non-immersed test pieces.

12 Test method for creep failure

12.1 Test pieces

12.1.1 Preparation, handling, and dimensions of test pieces

Test piece shall be prepared and handled in accordance with the provisions in [Clause 6](#).

12.1.2 Number of test pieces

Test at least three test pieces for each test condition. If a test piece fails at, or slips out of, the anchoring section, an additional test should be carried out on a separate test piece taken from the same lot as the failed test piece.

12.2 Testing frame and devices

12.2.1 Testing frame and devices

The testing frame and devices shall be capable of maintaining constant and sustained load, even if the test piece deforms.

12.2.2 Anchorage

The anchorage shall be in accordance with the provisions in [Clause 6](#).

12.2.3 Extensometer and strain gauge

The extensometer and strain gauge shall be in accordance with the provisions in [Clause 6](#).

12.2.4 Measurement of time

The passage of time during the test shall be measured with appropriate equipment (timer, etc.) with an accuracy of within 1 % of the elapsed time.

12.3 Test temperature

The temperature should be within the range $20\text{ °C} \pm 2\text{ °C}$, except in special circumstances. The temperature of $27\text{ °C} \pm 2\text{ °C}$ is applicable for warm countries.

12.4 Tensile capacity

The tensile capacity shall be calculated in accordance with the provisions in [Clause 6](#).

12.5 Test method

12.5.1 Mounting of test piece and gauge length

Mounting of the test pieces and gauge length shall be in accordance with the provisions in [Clause 6](#).

12.5.2 Loading

- Take care during loading to prevent the test piece from being subjected to any shock or vibration.
- Perform the loading promptly and record the initial loading time.

- The creep test measurement is considered to start at the moment when the prescribed loading to the test pieces has been completed.
- The creep force shall not be allowed to decrease by 2 % or more from the nominal figure.

12.5.3 Selection of sustained loads to be applied

- Conduct the creep tests for not less than five sets of load ratio conditions, selected on the basis of the tensile capacity.
- One set of load ratio conditions shall be such that three test pieces do not fail after 1 000 h of loading.

12.5.4 Measurement of creep strain

Creep strain shall be recorded automatically by a recorder attached to the testing machine. If no recorder is attached to the testing machine, measure and record the creep strain after the following times have elapsed: 1 min, 3 min, 6 min, 9 min, 15 min, 30 min, 45 min, 1 h, 1,5 h, 2 h, 4 h, 10 h, 24 h, 48 h, 72 h, 96 h, and 120 h; and subsequently, every 24 h with a minimum of one measurement every 120 h.

12.6 Calculations

12.6.1 Handling of data

Assess the material properties of FRP bars only on the basis of test pieces undergoing failure in the test section. If tensile failure or slippage has clearly taken place at the anchoring section, disregard the data; additional tests should be carried out until the number of test pieces failing in the test section is not fewer than three.

Disregard data of test pieces breaking at the start of loading. In such cases, record only the applied load and the creep failure time, but exclude them from the data; it is not necessary to perform additional tests.

12.6.2 Load ratio/creep failure time curve

For each test piece subjected to creep test, the load ratio/creep-failure time curve shall be plotted on a semi-logarithmic graph where the load ratio is represented on an arithmetic scale on the vertical axis and the creep-failure time, expressed in hours, is represented on a logarithmic scale on the horizontal axis.

12.6.3 Creep failure line chart

Prepare a creep-failure line chart based on the creep load ratio, R_{Yc} , and calculate the best-fit line for the graphed data using the least-squares method according to Formulae (12) and (15):

$$R_{Yc} = k_a - k_b \cdot \log t \quad (15)$$

12.7 Test report

The test report shall include the following items:

- a) name, shape, date of manufacture, and lot number of FRP tested;
- b) type of fibre and fibre-binding material;
- c) numbers or identification marks of test pieces;
- d) designation, nominal cross-sectional area, and diameter;
- e) date of test, test temperature;

- f) type and name of testing frame and devices;
- g) type and name of anchorage;
- h) average tensile capacity and tensile capacity (strength) for each test piece;
- i) initial loading time;
- j) load ratio/creep failure time curve;
- k) creep strain/time curve for each test piece;
- l) formula for derivation of the approximation line and its coefficient of determination.

13 Test method for transverse shear strength

13.1 Test pieces

13.1.1 Preparation of test pieces

Test pieces shall not be subjected to any processing and shall be as straight as possible. Severely bent test pieces should not be used.

13.1.2 Handling of test pieces

When obtaining and preparing test pieces, avoid all deformation, heating, and outdoor exposure to ultraviolet light, which can cause changes to the material properties of the test section of the test piece.

13.1.3 Length of test pieces

Test pieces shall be of constant length regardless of the nominal diameter of the FRP bars. The length shall not be less than five times the shear plane interval and not more than 300 mm.

13.1.4 Number of test pieces

Test at least three test pieces. If a test piece shows significant pull-out of fibres, indicating that failure is not due to shear, an additional test should be carried out on a separate test piece taken from the same lot as the failed test piece.

13.2 Testing machine and devices

13.2.1 Testing machine

The testing machine should conform to the requirements of ISO 7500-1. The testing machine shall have a loading capacity in excess of the tensile capacity of the test pieces and shall be capable of applying loading at the required loading rate. The testing machine shall also be capable of giving readings of loading accurate to within 1 % during the test.

13.2.2 Shear testing apparatus

The shear-testing apparatus (see [Figures 7 to 9](#)) shall be constructed so that a rod-shaped test piece is sheared on two planes more or less simultaneously by two blades (edges) converging along the faces perpendicular to the axial direction of the test piece. The discrepancy in the axial direction between the upper and lower blades shall be of the order of 0 mm to 0,5 mm, and shall be made as small as possible. The specified distance between shear planes shall be 50 mm.

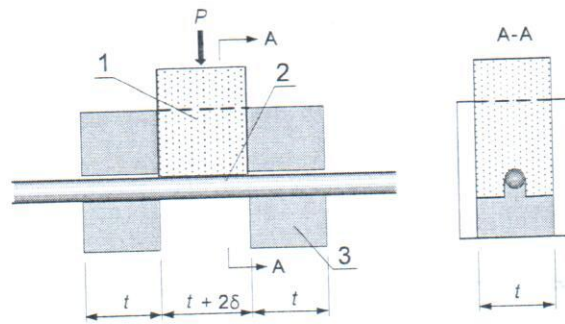

- Key**
- 1 push-in cutter
 - 2 test piece
 - 3 test piece holder

Figure 7 — Double shear test machine (transverse shear test)

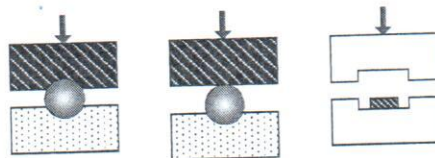
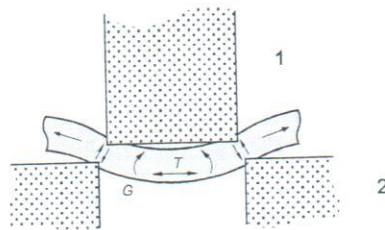

Figure 8 — Combinations of test pieces and test machine contact surfaces



- Key**
- 1 upper blade
 - 2 lower blade

Figure 9 — Conceptual diagram of contact stresses from the test apparatus acting on the test piece

13.3 Test temperature

The temperature should generally be within the range of 5 °C to 35 °C. The specified test temperature for test pieces sensitive to temperature shall be 20 °C ± 2 °C. The temperature of 27 °C ± 2 °C is applicable for warm countries.

13.4 Test method

13.4.1 Mounting of test piece

Mount the test piece in the centre of the shear apparatus, touching the upper loading device. No gap should be visible between the contact surfaces of the loading devices.

13.4.2 Loading rate

The specified loading rate shall be such that the shearing stress increases at a rate of 30 N/mm²/min to 60 N/mm²/min. Apply loading uniformly without subjecting the test piece to shock.

13.4.3 Scope of test

Continue loading until the test piece fails. Record the failure load with a precision of three significant digits. It should be noted that loading can decrease temporarily due to the presence of two rupture faces.

13.5 Calculations

13.5.1 Handling of data

Determine failure, whether or not it is due to shear, by visual inspection. If the pull-out of fibres is obvious, disregard the data; additional tests shall be carried out until the number of test pieces failing due to shear is not less than three.

13.5.2 Shear strength

Calculate the shear strength, τ_s , expressed in newtons per square millimetre, with a precision of three significant digits according to Formula (16):

$$\tau_s = \frac{P_s}{2A} \quad (16)$$

where

P_s is the shear failure load, expressed in newtons;

A is the nominal cross-sectional area of the test piece, expressed in square millimetres.

13.6 Test report

The test report shall include the following items:

- a) name of FRP;
- b) type of fibre and fibre-binding material;
- c) numbers or identification marks of test pieces;
- d) designation, nominal cross-sectional area, and diameter;
- e) date of test, test temperature, loading rate;
- f) interval between double shear faces and contact surface geometry;
- g) shear failure load for each test piece, average shear failure load and shear strength;
- h) failure mode of each test piece.

14 Test method for flexural tensile properties

14.1 Test pieces

14.1.1 Preparation and handling of test pieces

Prepare and handle test pieces in accordance with the provisions in [Clause 6](#).

14.1.2 Length of test pieces

The length of the test piece shall be the length of the test section added to the length of the anchoring section. The length of the test section shall be not less than 100 mm from the anchorages to the deflected section, and not less than 40 times the nominal diameter of the FRP bar. For an FRP bar in strand form, as an additional condition, the length shall be not less than 2 times the strand pitch.

14.1.3 Number of test pieces

The number of test pieces shall not be fewer than three for each test condition (combination of bending diameters and bending angles). If the test piece clearly fails at, or slips out of, the anchoring section under the tensile capacity of 95 %, an additional test shall be performed on a separate test piece taken from the same lot.

14.2 Testing unit and devices

14.2.1 Testing unit

The testing unit (see [Figure 11](#)) shall include a loading device, load indicator, anchorage holder, and deflector. The testing machine shall also have a structure capable of continuing the test up to the tensile failure.

14.2.2 Loading device

The loading device shall have a loading capacity in excess of the tensile capacity of the test piece and shall be capable of applying loading at the required loading rate.

14.2.3 Load indicator

The load indicator shall be capable of displaying loads with an accuracy of not less than 1 % of the failure load, up to the failure of the test piece.

14.2.4 Anchorage holder

The anchorage holder shall be suited to the geometry of the test piece and shall be capable of accurately transmitting loads from the testing machine to the test piece. It shall be structured so as to transmit only axial loads to the test piece, without transmitting either torsion or flexural force.

14.2.5 Deflector

The deflector shall be capable of maintaining the required bending angle and bending diameter during the test until failure of the test piece. The surface of the deflector in contact with the test piece shall be robust and smooth. See [Figure 10](#).

14.2.6 Test temperature

The specified test temperature shall be within the range 5 °C to 35 °C unless otherwise agreed. The test temperature for test pieces sensitive to temperature variations shall be 20 °C ± 2 °C. The temperature of 27 °C ± 2 °C is applicable for warm countries.

14.3 Test method

14.3.1 Test preparation

The bending diameter and bending angle shall be set appropriately for the test. This combination, then, forms a single test condition. As a specification configuration, only one deflected section shall be set up in the test piece.

14.3.2 Mounting of test piece

Take care when mounting the test piece on the testing unit to maintain the required bending angle and bending diameter at the deflected section during the test.

14.3.3 Loading rate

The standard loading rate shall be a constant strain rate equivalent to 1 % strain per minute \pm 0,5 %.

14.3.4 Scope of test

Apply loading until failure of the test piece. Measure and record the load and failure location and record the time of failure.

14.4 Calculations

14.4.1 Handling of data

Assess the material properties of FRP bar only on the basis of test pieces undergoing failure in the test section. In cases where tensile failure or slippage has clearly taken place at the anchoring section under the tensile capacity of 95 %, disregard the data.

14.4.2 Bending tensile capacity

Calculate the average, maximum, and minimum bending tensile capacity for each set of test conditions.

14.5 Test report

The test report shall include the following items:

- a) name, shape, date of manufacture, and lot number of FRP tested;
- b) type of fibre and fibre-binding material;
- c) numbers or identification marks of test pieces;
- d) designation, nominal cross-sectional area, and diameter;
- e) date of test, test temperature, loading rate;
- f) condition of surface of FRP bar (material, thickness, configuration, etc., of any coating);
- g) bending angle, external diameter of surface position of deflected section, bending diameter ratio, material and surface configuration;
- h) bending tensile capacity for each test piece;
- i) location and mode of failure for each test piece;
- j) number of test pieces for each set of conditions in 14.5 g), average, maximum, and minimum bending tensile capacity.

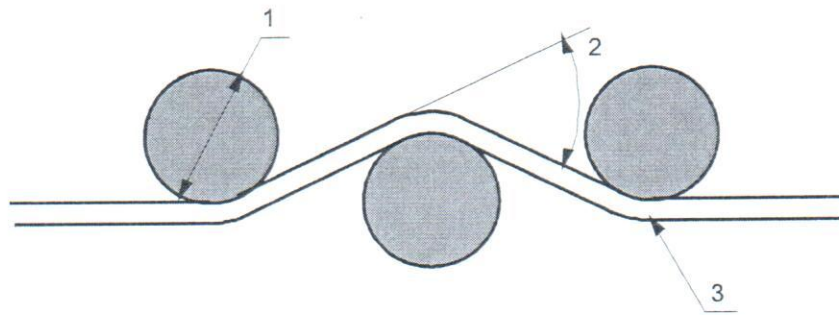

- Key**
- 1 bending diameter
 - 2 bending angle
 - 3 FRP bar

Figure 10 — Example of deflector

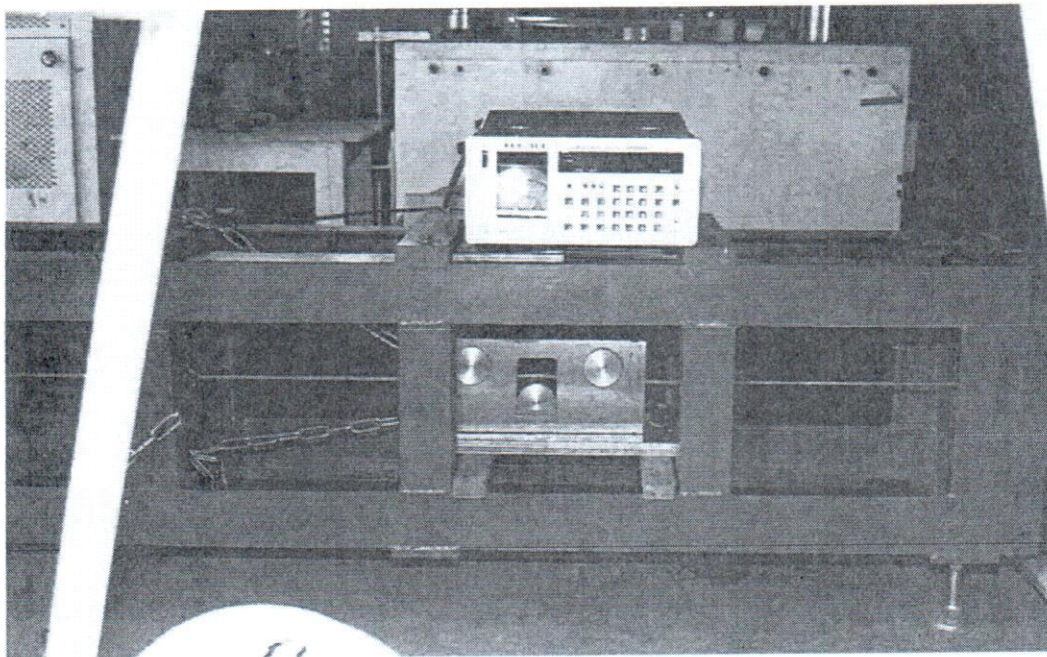

Figure 11 — Photo of testing unit and devices

15 Test method for the coefficient of longitudinal thermal expansion by thermo-mechanical analysis

15.1 Test pieces

15.1.1 Pretest curing of test pieces

Prior to testing, test pieces shall be kept for a minimum of 24 h at a temperature of $23\text{ °C} \pm 2\text{ °C}$ and a relative humidity of $(50 \pm 10)\%$, under class 2 temperature and relative humidity conditions, in accordance with ISO 291:2008, Clause 6, unless otherwise agreed. The test pieces shall then normally

be kept for 48 h at the maximum test temperature in order to eliminate strain resulting from bending and for dehumidification and deaeration.

15.1.2 Dimensions of test pieces

The specification test piece cut from the FRP bar shall be 20 mm in length, with a round or square cross-section having a diameter or breadth of not more than 5 mm.

15.1.3 Number of test pieces

The number of test pieces shall not be fewer than three.

15.2 Testing device

15.2.1 Testing device

The thermomechanical analysis (TMA) apparatus used for testing shall be capable of measuring in compression mode, of maintaining a constant atmosphere around the test piece, and of raising the temperature of the test piece at a constant rate.

15.2.2 Calibration of testing device

Sensitivity calibration of the displacement gauge shall be carried out periodically using either an external micrometer in accordance with ISO 3611, or a micrometer attached to the testing machine.

Calibration of the temperature gauge shall be carried out using a pure substance of known melting point.

15.2.3 Installation of testing device

The TMA apparatus shall be installed in a location that is not subject to vibration during testing.

15.3 Test method

The test procedure is as follows.

- a) Clean the test piece, gauge rod, and test platform and place the test piece upright and, if possible, bonded to the platform.
- b) Place the gauge rod in the centre of the test piece, with no pressure applied.
- c) The atmosphere around the test piece shall consist of dry air (water content not more than 0,1 % mass fraction) or nitrogen (water content not more than 0,001 % mass fraction, oxygen content not more than 0,001 % mass fraction), maintained at a flow rate in the range of 500 ml/min to 100 ml/min.
- d) Apply the load gently to the tip of the gauge rod at room temperature; the temperature shall first be lowered to 0 °C, then raised to 60 °C, unless otherwise agreed, and the full process of displacement of the test piece shall be recorded.
- e) The rate of temperature increase shall not be more than 5 °C/min.
- f) The compressive stress acting on the test piece shall be around 3 mN/mm².

15.4 Calculations

15.4.1 Coefficient of thermal expansion

The coefficient of thermal expansion, α_{sp} , expressed in reciprocal degrees Celsius, of the test piece within the measured temperature range T_1 to T_2 shall be calculated according to Formula (17):

$$\alpha_{sp} = (\Delta L_{spm} - \Delta L_{refm}) / [L_0 \times (T_2 - T_1)] + \alpha_{set} \quad (17)$$

where

- ΔL_{spm} is the difference in the length of test piece between temperature T_1 and temperature T_2 , expressed in micrometres;
- ΔL_{refm} is the difference in length of the specification test piece for length calibration between temperature T_1 and temperature T_2 , expressed in micrometres;
- L_0 is the length of the test piece at room temperature, expressed in micrometres;
- T_2 is the maximum temperature for calculation of the coefficient of thermal expansion, normally 60 °C;
- T_1 is the minimum temperature for calculation of the coefficient of thermal expansion, normally 0 °C;
- α_{set} is the coefficient of thermal expansion calculated for the specification test piece for length calibration between temperatures T_1 and T_2 , expressed in reciprocal degrees Celsius.

For apparatus in which the test piece and specification test piece for length calibration are measured simultaneously, ΔL_{refm} shall be equal to 0 in Formula (17).

15.4.2 Rounding-off of numerical values

Each of the coefficients of thermal expansion shall be calculated to six decimal places (10^{-7}), and the average value rounded off to five decimal places (10^{-6}). If the average value is less than 1, it shall be expressed accurately to six decimal places (10^{-7}).

15.5 Test report

The test report shall include the following items:

- a) name, shape, date of manufacture, and lot number of FRP tested;
- b) type of fibre and fibre-binding material;
- c) numbers or identification marks of test pieces;
- d) designation, nominal cross-sectional area, and diameter;
- e) date of test;
- f) dimensions of test pieces;
- g) pretest curing method;
- h) type of testing machine;
- i) type of ambient atmosphere during test and flow rate;

- j) name of substance used for temperature calibration and measurements taken;
- k) type of specification test piece for length calibration;
- l) temperature range for which the coefficient of thermal expansion was measured and representative temperature;
- m) TMA curve for each test piece;
- n) coefficient of thermal expansion for each test piece and average coefficient of thermal expansion.

ISO 10406-1:2015(E)

ICS 91.100.30;83.120

Price based on 39 pages

© ISO 2015 - All rights reserved